



Filter Control

	402-A8 4 Output	802-A6 10 Output	802-A4 16 Output	802-A4 20 Output
Input of Power Supply	220 V.AC.			
Out Put (Power Rating) Max	Triac 3 Amp.			
Number Of Out Put	4 OutPut	10 OutPut	16 OutPut	20 OutPut
Operating Temperature	-20 to +60dg.C	-20 to +60dg.C	-20 to +60dg.C	-20 to +60dg.C
Pulse Time	0.1 to 1 Sec.	0.1 to 1 Sec.	0.1 to 1 Sec.	0.1 to 1 Sec.
Pause Time	1 to 59 Sec.	1 to 59 Sec.	1 to 59 Sec.	1 to 59 Sec.
Dimension (mm.)/(thk=52mm.)	A8 130 x 170	A6 200 x 230	A4 230 x 350	A4 230 x 350
Weight (Kg)	0.72	1.4	2.06	2.09
For Filter Model	BinVent / Spot / HandAdd / JM9 / JM7 / JM10 / JM14	Intake/JM21/JM32/ JM41/JM42/JM52	JM70/JM90	JM124/JM170/JM198

DUST COLLECTOR CONTROLLER STAND ALONE

The proportional economist design for the command and the control of the small and medium size of dust collector system especially Bags house or filter bag system.

This controller is instigated of microprocessor provide out put up to 20 solenoid valve control. The function can be connecting with ΔP measurement for pressure drop demand on Filter bags. The program is design for easy programming on the function. The system can start up with the remote contact as well as by the switching off of the fan, to obtain the final cleaning cycle up to 9 cycles.

The special offline function has been integrated. The offline function in advance for reduce up stem velocity when cleaning filter bags.



Control Box

Features

- Compact electronic sequential controllers for up to 20 output
- Regulation of the pulse time and the pause time, with indication on the display.
- Easy Program and Adjustable.
- Out put in semiconductor technology suitable to control solenoid in 220 VAC
- In put to start or stop the sequence from external contact from ΔP measurement
- Setting number of end cycle cleaning. The final cleaning can start up with a remote contact
- as well as by switching off the fan.
- LED indicator for out put signal and for function mode
- Electrically protect by a fuse
- Longer life time
- Construction in PC Case IP 56

SIMATEK CO., LTD.



20/9 M6. Soi Chatu Chot 4, Chatu Chot Rd.,
Or-Nerng, Saimai, Bangkok 10220 THAILAND.
Tel: +66 2974 5630 Fax: +66 2974 5640

www.simatekasia.com www.simatek.co.th
e-mail : office@simatekasia.com

Standard Control

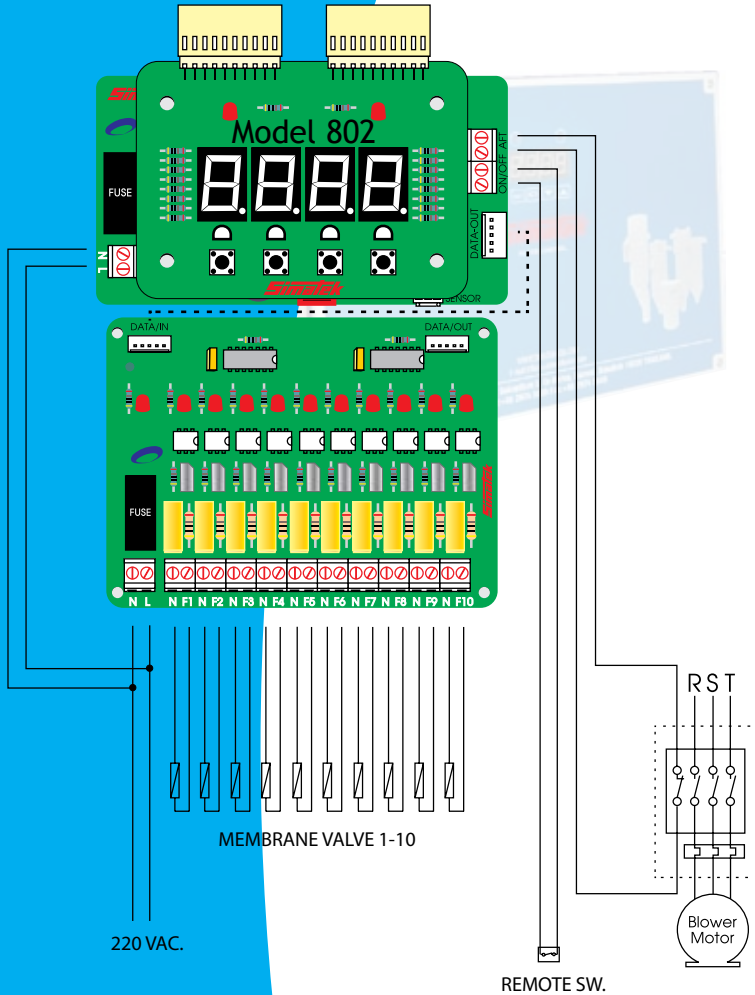

Off-Line Control

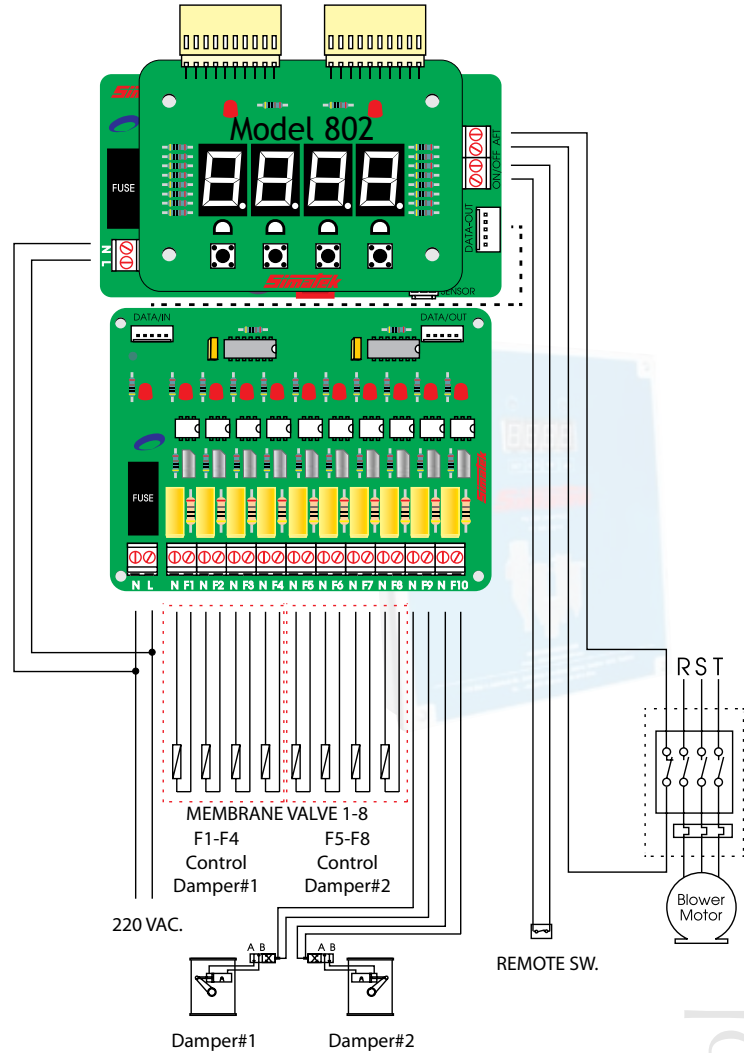

Standard Control

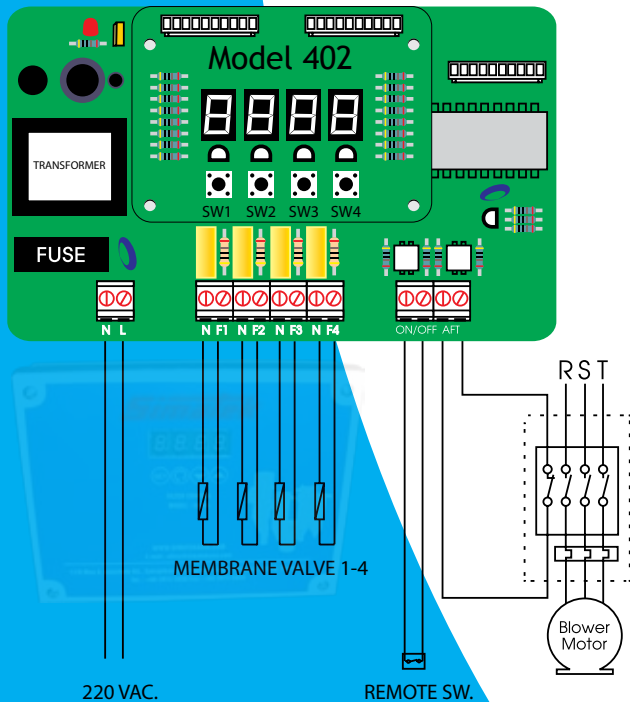

SIMATEK CO., LTD.

20/9 M6. Soi Chatu Chot 4, Chatu Chot Rd.,
Or-Nerng, Saimai, Bangkok 10220 THAILAND.
Tel:+66 2974 5630 Fax:+66 2974 5640

www.simatekasia.com www.simatek.co.th
e-mail : office@simatekasia.com

Agent / Distributors :